



HEIDENHAIN



Preliminary
Product Information

TD 110

Tool Breakage Detector
for Machine Tools

TD 110 tool breakage detector

Fast and reliable tool breakage inspection

- Non-contact tool detection at rapid traverse
- Resistant to contamination and coolant
- Suitable for tools with at least $\varnothing 0.4$ mm made of HSS or carbide
- Deployable on all types of CNC control

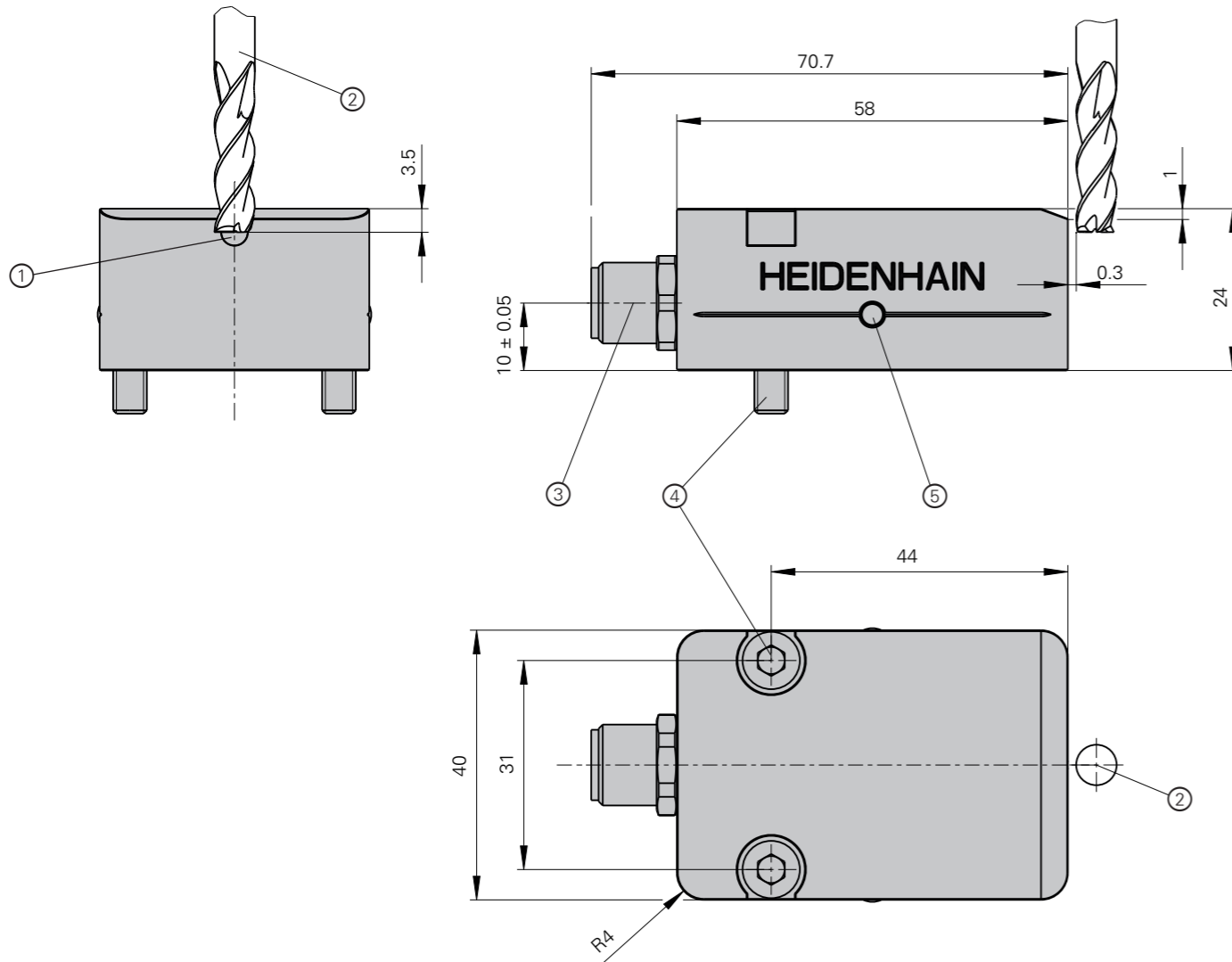

- 1 = Surface of sensor
- 2 = Tool to be measured
- 3 = 8-pin M12 cable connection
- 4 = Two M5 x 25 cylinder head screws; tightening torque: 6.0 Nm
- 5 = LED status indicator

mm
Tolerancing ISO 8015
ISO 2768:1989-mH
≤ 6 mm: ±0.2 mm

Specifications	TD 110
Type of mounting	Mounting holes
Electrical connection	8-pin M12 flange socket
Supply voltage	10 V to 30 V
Output signal	HTL (switching signal S, \bar{S}) Floating switching outputs (NC, NO)
Cable length	≤ 30 m
Vibration 55 Hz to 2000 Hz Shock 6 ms	≤ 200 m/s ² (EN 60068-2-6) ≤ 300 m/s ² (EN 60068-2-27)
Operating temperature	10 °C to 50 °C
Storage temperature	-20 °C to 70 °C
Protection rating	IP66/68
Mass	≈ 0.24 kg

Application

The tool breakage detector can be positioned in the work envelope such that it is easily accessible during tool changes at rapid traverse. The inductive sensor can detect tools as they pass by while they are spinning at their operational speed, or at least at 1000 rpm. Thanks to its rapid scanning technology, even very small tools made of HSS steel or carbide are detected. For use on all controls, the breakage sensor generates a floating trigger signal and an HTL switching signal. The control can evaluate these signals via standardized instruction sets. In addition, an LED indicates whether a tool has been detected. As a result, machines already in use can benefit from automated breakage detection as well.

Advantages

- Non-cutting time for breakage inspection is reduced by up to six seconds.
- The wear-free TD 110 is unaffected by coolant and contamination.
- Tools do not need to be cleaned for reliable tool inspection.
- Reduction of system costs and carbon emissions due to not needed purge air (unlike laser systems).

Connecting to TNC controls

The tool breakage detector can be connected via the cables for the TT 160 touch probe to the touch probe input X112/ X113 of the PLB, UEC or UMC, and to X12/ X13 of the iTNC 530. Our Service team provides optimal support for the operation of HEIDENHAIN controls, including cycles for breakage detection that can be added via TNCremo. Please contact the HEIDENHAIN Service team:

Remote support
service.nc-pgm@heidenhain.de
ID 1369787-35

Requirements for retrofitting:

- TNC option: Touch Probe Functions
- Touch probe for setting up the TD 110

One of the following controls:

- TNC7 with NC SW 817620-16 or later
- TNC 640 with NC SW 34059x-07 or later
- TNC 620 with NC SW 81760x-04 or later
- iTNC 530 with NC SW 340490-03 or later
- iTNC 530 with NC SW 606420-01 or later

Upon request:

- TNC 320 with NC SW 771851-04 or later
- TNC 128 with NC SW 771841-05 or later

Connection to other CNC controls

The HTL switching signals and the floating outputs can be used for connection to the PLC or to other IO connections of nearly every CNC control (assistance from the machine manufacturer may be necessary). For information about programming cycles, refer to the TD 110 documentation.

Fast and versatile mounting

Installing the tool breakage detector at the tool change position enables very fast changing times and maximum reduction in non-cutting time. The different detection paths permit various possibilities for installing the TD 110 in the work envelope. In the simplest case, the TD 110 is mounted at the edge of the machine table.

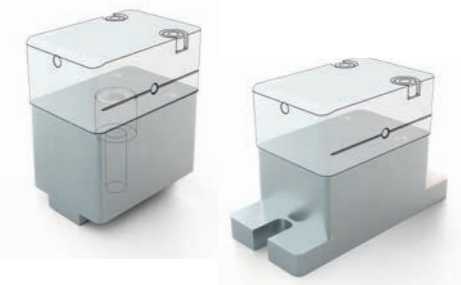

Mounting examples using customer's base

Detection

Horizontal mounting

The drill points and corner radii are accounted for via a linear offset, and the tool radius is taken into account by the cycle.



Passing by
The tool passes by the tool breakage detector from the side (three-axis motion). Very short cycle times are possible.



Approaching
The sensor surface of the TD 110 is approached from the front up to the operating distance (two-axis motion). The tool can then be moved away in a vertical upward motion.



Plunging
The tool plunges into the sensor's range from above (two-axis motion). This scenario is especially advantageous if the TD 110 is mounted on the same portal as the spindle.

Supported tools	Passing by	Approaching	Plunging
Type	End mills, drills, taps, thread formers, ball-nose cutters, radius cutters		
Material	Carbide, HSS		
Minimum diameter for nominal scanning distance	0.4 mm	0.5 mm to 1 mm	1 mm
Minimum rotational speed (recommended)	1000 rpm	5000 rpm	1000 rpm
Feed rate (Rapid traverse recommended)	≥ 3 m/min	≥ 20 m/min	≥ 3 m/min
Operating distance	≤ 0.5 mm (nominal: 0.3 mm)		
Minimum tooth length	2.5 mm		
L-OFFSET	Corner radius or corner chamfer, if > 1 mm		
Breakage criteria	<ul style="list-style-type: none"> • Complete tool breakage: 2 mm (+ L-OFFSET) • No breakage of individual teeth or cutting inserts 		

Vertical mounting

If the tool radius (for example, of a drill) is not available in the control's tool table, then the TD 110 can be mounted vertically.



Passing by
The tool breakage detector is installed in alignment with the tool axis. The tool passes by the sensor parallel to the housing's upper edge (two-axis motion). Very short cycle times are possible.

The machine manufacturer can also adapt the tool inspection cycle to other mounting situations while still supporting the same tools. Standardized instruction sets are used to evaluate the switch signal.



Illustrative videos with the system in action

Supported tools	Passing by
Type	End mills, drills, taps, thread formers, ball-nose cutters, radius cutters
Material	Carbide, HSS
Minimum diameter for nominal scanning distance	0.6 mm to 1 mm ≥ 1 mm
Minimum rotational speed (recommended)	5000 rpm 1000 rpm
Feed rate (Rapid traverse recommended)	≥ 20 m/min ≥ 3 m/min
Operating distance	≤ 0.5 mm (nominal: 0.2 mm)
Minimum tooth length	2 mm
L-OFFSET	Note: The tool must be measured all the way to the tip
Breakage criteria	<ul style="list-style-type: none"> • Complete breakage: 2 mm • No breakage of individual teeth or cutting inserts

Electrical connection

Signal behavior

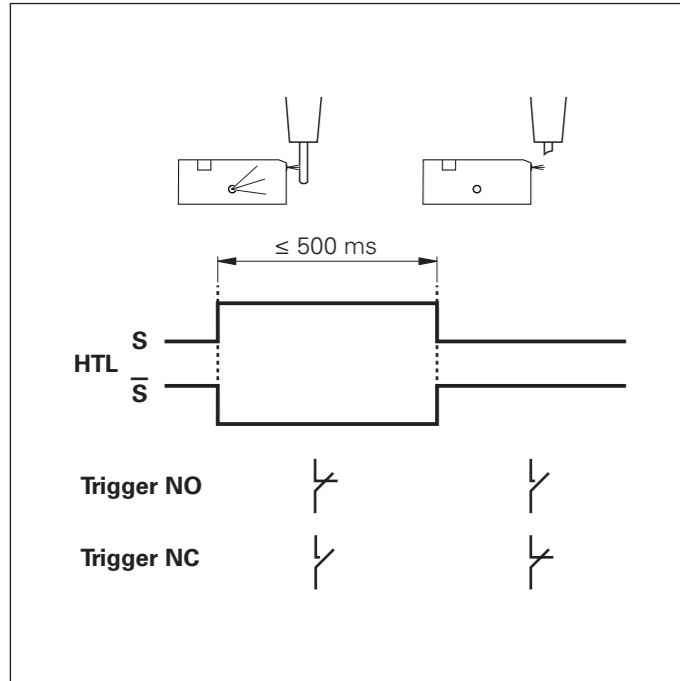

Circuit diagram

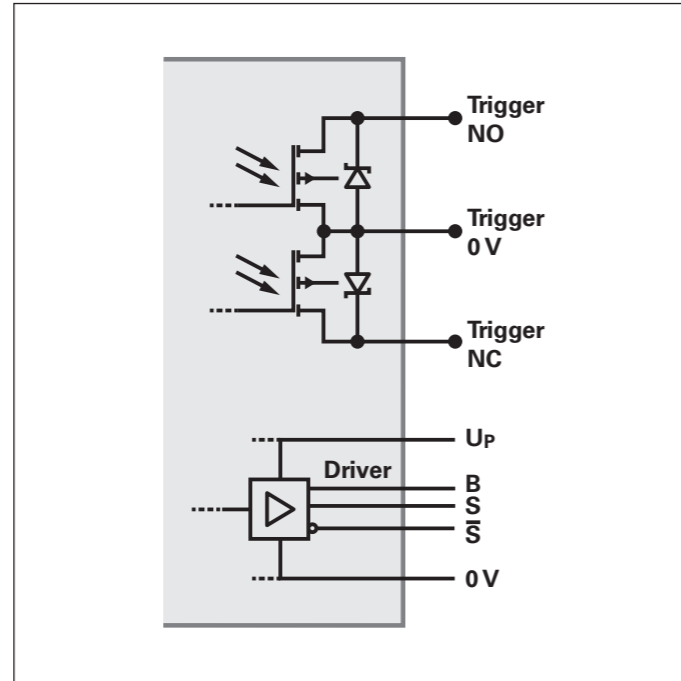

Pin layout

8-pin M12 connector (female)								
	2	7	3	4	1	5	6	8
	Up	0V	S	\bar{S}	B	Trigger NO	Trigger NC	Trigger 0V
	Blue	Violet	Gray	Pink	White	White/Green	Yellow	Brown/Green

Further information:

See the Installation Instructions for a connection example and further information.

Adapter cables for TNC controls

1 x (4 x 0.16 mm ²) + 4 x 0.34 mm ²		Ø 6 mm	Ø 10 mm
With 8-pin M12 connector (female) and 15-pin, 3-row D-sub connector (male) (PLB) ¹⁾		1070794-xx	–
With 8-pin M12 connector (female) and 9-pin, 2-row D-sub connector (male) (X13 on iTNC without HSCI)		1070793-xx	–
With 8-pin M12 connector (female) and 15-pin, 2-row D-sub connector (male) (X12 on iTNC without HSCI)		745454-xx	–

¹⁾ For connection to the PLB 62xx, UEC 11x, UMC 11x: X112, X113

Connecting cables

1 x (4 x 0.16 mm ²) + 4 x 0.34 mm ²		Ø 6 mm	Ø 10 mm
with 8-pin M12 connector (female) and 8-pin M12 coupling (male)		368330-xx	–
With 8-pin M12 right-angle connector (female) and 8-pin M12 coupling (male)		373289-xx	–
With 8-pin M12 right-angle connector (female) and unstripped cable end		606317-xx	–
With 8-pin M12 connector (female) and unstripped cable end		634265-xx	–
With 8-pin M12 connector (female) and 8-pin M12 coupling (male), with protective armor		–	660042-xx
With 8-pin M12 connector (female), partially with protective armor, stripped cable end		–	1083190-xx
With 8-pin M12 right-angle connector (female) and 8-pin M12 coupling (male), with protective armor		–	1395683-xx

Wall duct

M12, 8-pin

ID 1142270-01



HEIDENHAIN

DR. JOHANNES HEIDENHAIN GmbH

Dr.-Johannes-Heidenhain-Straße 5

83301 Traunreut, Germany

 +49 8669 31-0

 +49 8669 32-5061

info@heidenhain.de

www.heidenhain.com

This Product Information document supersedes all previous editions, which thereby become invalid. The basis for ordering from HEIDENHAIN is always the Product Information document edition valid when the order is placed.



Further information:

Comply with the requirements described in the following documents to ensure correct and intended operation:

- Brochure: *Touch Probes for Machine Tools* 1113984-xx
- Brochure: *Cables and Connectors* 1206103-xx
- Brochure: *Interfaces of HEIDENHAIN Encoders* 1078628-xx