

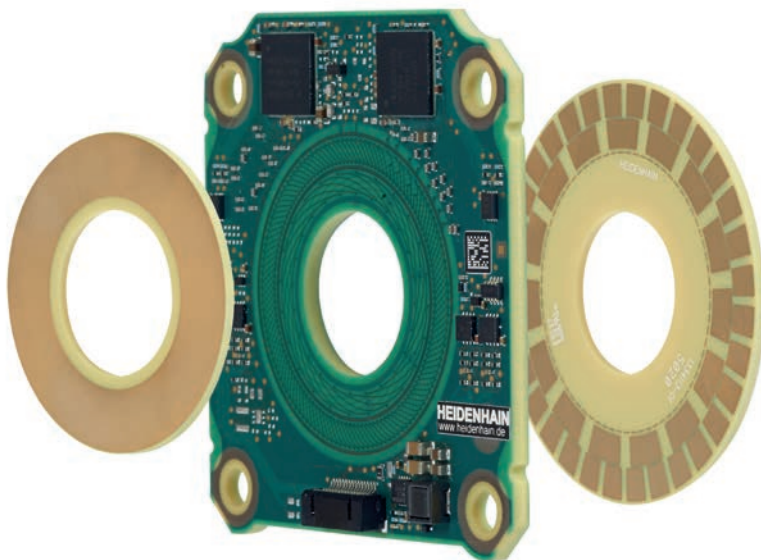

# HEIDENHAIN



Product Information

## **KCI 120 *Dplus***

Absolute Inductive Rotary Encoder with Additional Functionality:

Position measurement of output side

# KCI 120 Dplus

Absolute inductive rotary encoder with additional functionality

- Robust inductive scanning principle
- Consisting of an AE scanning unit and two rotor units (circular scale)
- Position measurement of output side

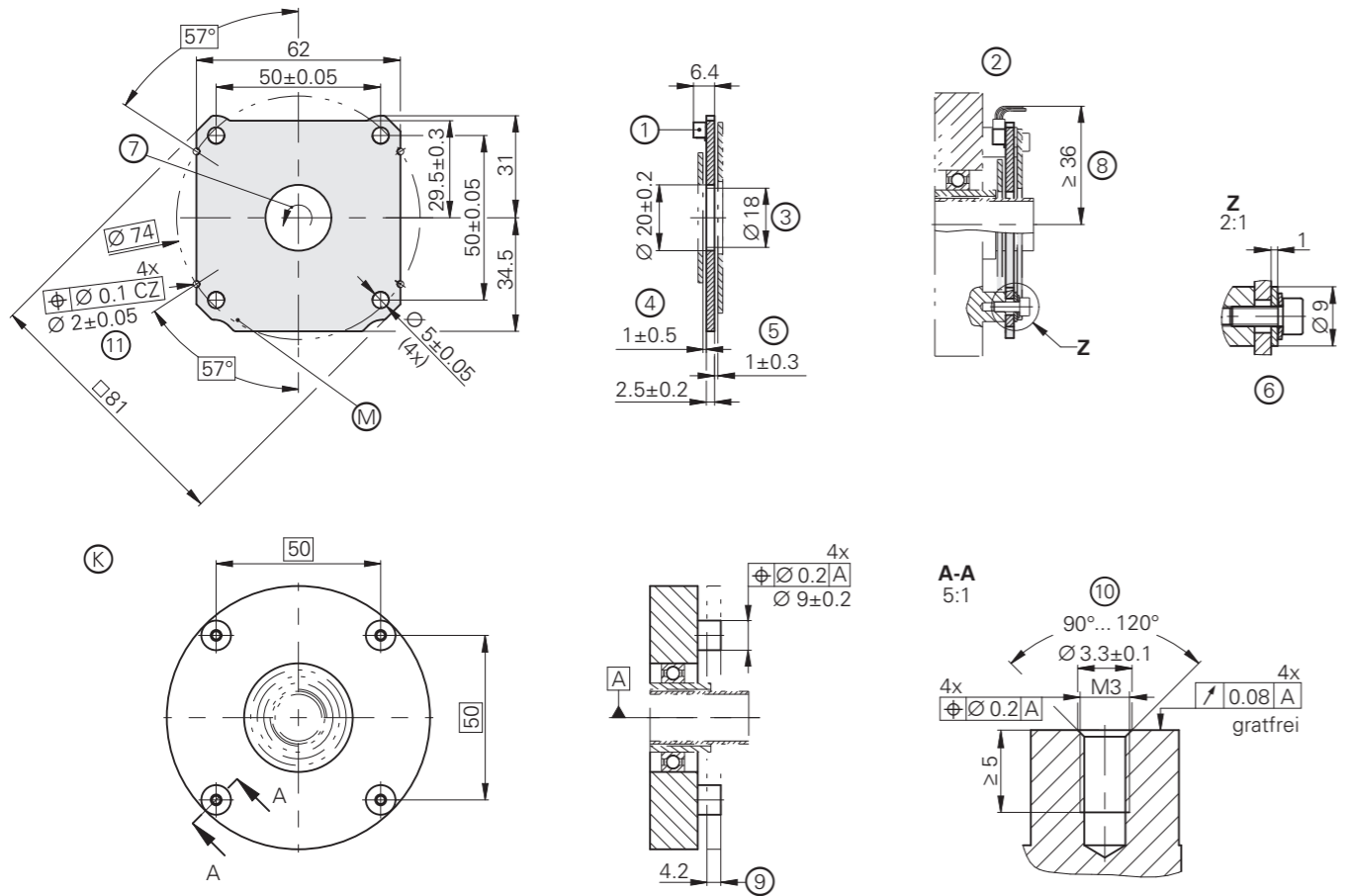
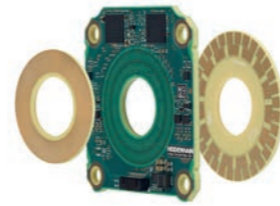

- ⊠ = Bearing of mating shaft
- ⊙ = Required mating dimensions
- M = Measuring point for operating temperature and vibration
- 1 = 15-pin PCB connector
- 2 = Shown with customer side
- 3 = Max. permissible hole diameter for non-isolated electrically conductive parts; avoid passage of segmented shafts through the hole
- 4 = Encoder B mating dimension (motor side); tolerance includes compensation of mounting tolerances and thermal expansion; dynamic motion permitted over entire tolerance range
- 5 = Encoder A mating dimension (output side); tolerance includes compensation of mounting tolerances and thermal expansion; dynamic motion permitted over entire tolerance range
- 6 = ISO 4762 or ISO 14583 – M3x8 – 8.8 – MKL\* (4x) with DIN 6796 – 3 – FSt (4x) spring washer and DIN 7349 – 3.2 – A2 (4x) washer; tightening torque: 1 Nm ±0.1 Nm; ensure proper orientation of the spring washer: convex side must face the screw head
- 7 = Direction of rotation of both shafts for ascending position values
- 8 = Ensure installation space for cable
- 9 = Ensure space for electronics; see also the mating dimension model
- 10 = Chamfer at start of thread is obligatory for materially bonding anti-rotation lock
- 11 = Holes for aligning the scanning unit via a device or to the motor-side geometry; centered position relative to reference ⊠ after assembly:  $\boxed{\text{⌀ } 0.2 \text{ CZ}}$
- 12 = Graduation side of circular scale
- 13 = Mounting side of circular scale
- 14 = On the fine track (Ø 31.0 mm to Ø 38.5 mm), after mounting
- 15 = On the fine track (Ø 48.0 mm to Ø 57.0 mm), after mounting
- 16 = Centering circle of circular scale after mounting:  $\boxed{\text{⌀ } 0.3 \text{ A}}$
- 17 = Centering circle of circular scale after mounting:  $\boxed{\text{⌀ } 0.2 \text{ A}}$

\*For instructions regarding screws with material bonding anti-rotation lock as per DIN 267-27, see *General mechanical information* in the *Rotary Encoders* brochure (these screws not included!)

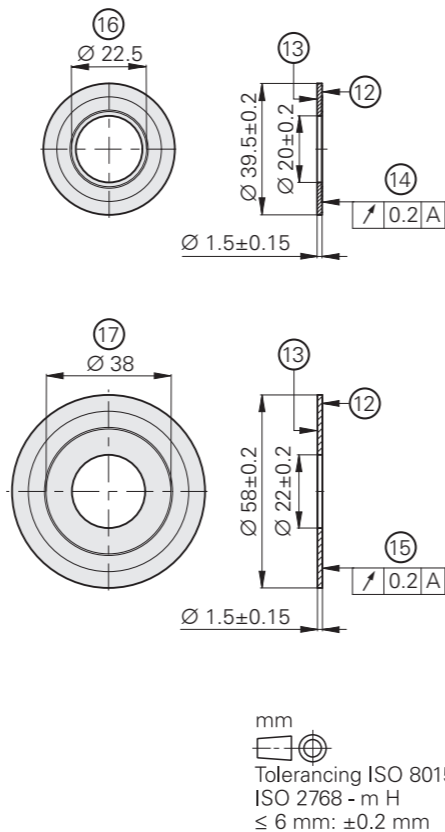

mm  
  
 Tolerancing ISO 8015  
 ISO 2768 - m H  
 ≤ 6 mm: ±0.2 mm

# General information

Specifications	KCI 120 Dplus	
<b>Interface</b>	EnDat 2.2	
Ordering designation	EnDat22	
Calculation time $t_{cal}$ Clock frequency	≤ 5 μs ≤ 16 MHz	
<b>Electrical connection</b>	15-pin PCB connector (radial); cable length ≤ 10 m <sup>1)</sup>	
Supply voltage	DC 3.6 V to 14 V (for both axes together)	
Power consumption (max.) <sup>2)</sup>	At 3.6 V: ≤ 1.2 W At 14 V: ≤ 1.4 W	
Current consumption (typical)	At 5 V: 180 mA (without load)	
<b>Vibration</b> 55 Hz to 2000 Hz <sup>3)</sup> <b>Shock</b> 6 ms	AE scanning unit: ≤ 400 m/s <sup>2</sup> ≤ 2000 m/s <sup>2</sup> (EN 60068-2-27)	
<b>Operating temperature</b>	–40 °C to 115 °C	
<b>Relative humidity</b>	≤ 93 % (40 °C/21 d as per EN 60068-2-78), condensation excluded	
<b>Protection rating</b> EN 60529	IP00 (read about insulation under <i>Electrical safety</i> in the <i>Interfaces of HEIDENHAIN Encoders</i> brochure)	
<b>Mass</b>	≈ 0.03 kg (scanning unit and rotors)	
<b>ID number</b>	<i>Individual packaging:</i> ID 1334444-01 (AE scanning unit) ID 1334113-01 (circular scale: Encoder A) ID 1332066-01 (circular scale: Encoder B)	<i>Collective package:</i> ID 1334444-51 (AE scanning unit) ID 1334113-51 (circular scale: Encoder A) ID 1332066-51 (circular scale: Encoder B)

- <sup>1)</sup> See pin layout for encoder
- <sup>2)</sup> See *General electrical information* in the *Interfaces of HEIDENHAIN Encoders* brochure, or visit [www.heidenhain.com](http://www.heidenhain.com)
- <sup>3)</sup> Scanning unit: 10 Hz to 55 Hz, 6.5 mm constant peak to peak  
Rotors: 10 Hz to 55 Hz, 10 mm constant peak to peak

# Position measurement

Specifications	KCI 120 Dplus singleturm Output side (Encoder A)	KCI 120 Dplus singleturm Motor side (Encoder B)
Shaft speed	≤ 6000 rpm	≤ 15000 rpm
Moment of inertia of circular scale	$3.7 \cdot 10^{-6} \text{ kgm}^2$	$0.8 \cdot 10^{-6} \text{ kgm}^2$
Axial motion <sup>1)</sup>	±0.3 mm	±0.5 mm
Position values per revolution	1 048 576 (20 bits)	524 288 (19 bits)
<b>System accuracy</b> <sup>2)</sup>	±40"	±120"

- <sup>1)</sup> Including thermal linear expansion and mounting tolerance
- <sup>2)</sup> At the stated radial runout of the circular scale

# Mounting

## Mounting and protection rating

### Mounting and protection rating

Mounting of the KCI 120 Dplus is performed through the mounting of two circular scales that are fastened, for example, to the relevant shafts with plane surfaces or to the customer-side hub mounted to the shaft. The scanning unit is mounted to the customer-side mounting surface via four holes.

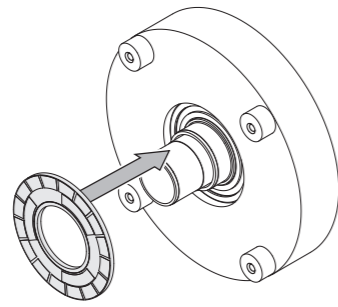

Circular scale (Encoder B)

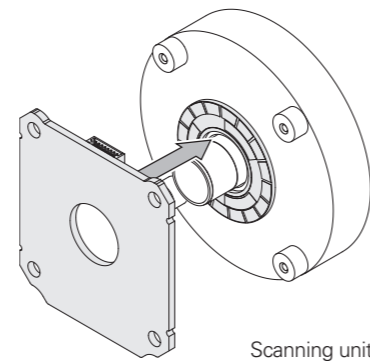

Scanning unit

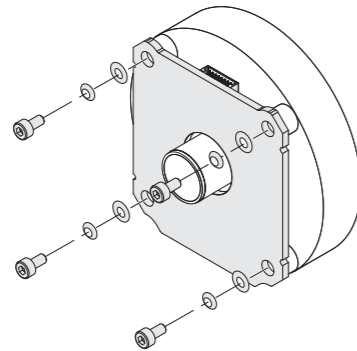

Scanning unit (mounted)

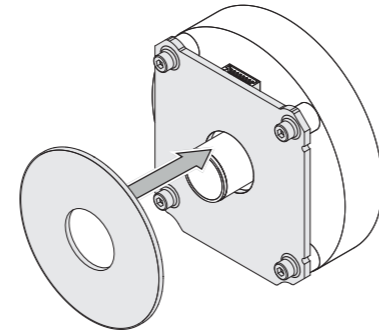

Circular scale (Encoder A)

### More information:

To ensure proper operation, comply with the measures in the *General electrical information* under *Electromagnetic compatibility* in the *Interfaces of HEIDENHAIN encoders* brochure.

### Mounting tool

To avoid damage to the cable, use the mounting aid to disconnect the cable assembly. Apply pulling force only to the connector of the cable assembly and not to the wires.

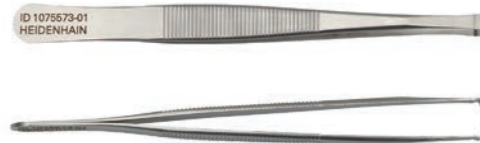

ID 1075573-01

### Mounting accessories

M3 ISO 4762 – 8.8 MKL screws and  
DIN 6796 - 3 - FSt. spring washers  
Washers: 3.2 DIN 7349 - A2

Instructions for use: use screws with material bonding anti-rotation lock as per DIN 26727 (see *General mechanical information* in the *Rotary Encoders* brochure). Fastening screws, spring washers, and washers are not included in delivery.

For more mounting information and mounting aids, see the *Mounting Instructions* and the *Encoders for Servo Drives* brochure. The mounting quality can be checked with the PWM 21 and the ATS software (see document ID 1082415).

# Electrical resistance

Check the electrical resistance between the customer-side stator and both customer-side shafts. Nominal value: < 1 ohm

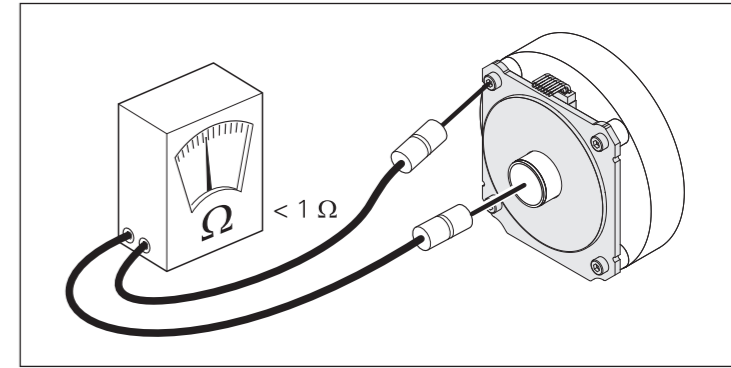

# Testing and inspection devices, and diagnostics

HEIDENHAIN encoders provide all of the information needed for initial setup, monitoring, and diagnostics. The type of information available depends on whether the encoder is incremental or absolute and on which interface is being used.

Absolute encoders employ serial data transmission. The signals are extensively monitored within the encoder. The monitoring results (particularly valuation numbers) can be transmitted to the subsequent electronics along with the position values via the serial interface (**digital diagnostics interface**). The following information is available:

- Error message: position value is not reliable
- Warning: an internal functional limit of the encoder has been reached
- Valuation numbers:
  - Detailed information about the encoder's function reserve
  - Identical scaling for all HEIDENHAIN encoders
  - Cyclic reading capability

The downstream electronics are able to evaluate the current status of the encoder with low resource expenditure, including in closed-loop operation.

For the analysis of these encoders, HEIDENHAIN offers the appropriate PWM inspection devices and PWT testing devices. Based on how these devices are integrated, a distinction is made between two types of diagnostics:

- Encoder diagnostics: the encoder is connected directly to the inspection or testing device, thereby enabling a detailed analysis of encoder functions.

- Monitoring mode: the PWM inspection device is inserted within the closed control loop (via suitable testing adapters as needed). This enables real-time diagnosis of the machine or equipment during operation. The available functions depend on the interface.

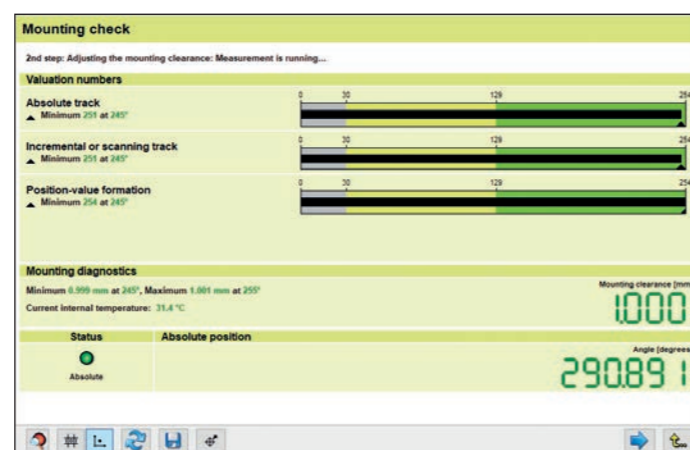

Mounting accuracy with the PWM 21 and the ATS software

## PWM 21

The PWM 21 phase-angle measuring unit, in conjunction with the included ATS adjusting and testing software, serves as an adjusting and testing package for the diagnosis and adjustment of HEIDENHAIN encoders.



	PWM 21
<b>Encoder input</b>	<ul style="list-style-type: none"> <li>• EnDat 2.1, EnDat 2.2, or EnDat 3 (absolute value with or without incremental signals)</li> <li>• DRIVE-CLiQ</li> <li>• Fanuc Serial Interface</li> <li>• Mitsubishi high speed interface</li> <li>• Yaskawa Serial Interface</li> <li>• Panasonic serial interface</li> <li>• SSI</li> <li>• 1 V<sub>PP</sub>/TTL/11 μA<sub>PP</sub></li> <li>• HTL (via signal adapter)</li> </ul>
<b>Interface</b>	USB 2.0
<b>Supply voltage</b>	AC 100 V to 240 V or DC 24 V
<b>Dimensions</b>	258 mm × 154 mm × 55 mm

DRIVE-CLiQ is a registered trademark of Siemens AG.

For more information, see the *PWM 21/ATS Software* Product Information document.

# Electrical connection

For connection to the PWM 21 diagnostic and testing device, Encoder A (output side) and Encoder B (motor side) each require a different special testing cable.

HEIDENHAIN offers two testing cables for this purpose. As a result, either a testing cable for the output-side encoder or a testing cable for the motor-side encoder can be connected to the PWM 21 as needed.

## Pin layout of the testing cables

Testing cable for connection to Encoder A: 1311046-xx

15-pin PCB connector		Power supply				Serial data transmission (Encoder A)			
Pin	Signal	Pin	Signal	Pin	Signal	Pin	Signal	Pin	Signal
15	0V	14	Sensor 0V	13	U <sub>P</sub>	11	Sensor U <sub>P</sub>	7	DATA A
	White/Green		White		Brown/Green		Blue	8	DATA A
								9	CLOCK A
								10	CLOCK A
									Gray
									Pink
									Violet
									Yellow



U<sub>P</sub> = Power supply  
Vacant pins or wires must not be used!

Testing cable for connection to Encoder B: 1311047-xx

15-pin PCB connector		Power supply				Serial data transmission (Encoder B)			
Pin	Signal	Pin	Signal	Pin	Signal	Pin	Signal	Pin	Signal
15	0V	14	Sensor 0V	13	U <sub>P</sub>	11	Sensor U <sub>P</sub>	1	DATA B
	White/Green		White		Brown/Green		Blue	2	DATA B
								3	CLOCK B
								4	CLOCK B
									Gray
									Pink
									Violet
									Yellow

U<sub>P</sub> = Power supply  
Vacant pins or wires must not be used!

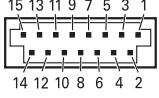
## Pin layout for the rotary encoder

15-pin PCB connector											
											
Power supply				Serial data transmission (Encoder A)				Serial data transmission (Encoder B)			
14	12	13	11	7	8	9	10	1	2	3	4
0V	Sensor 0V	U <sub>P</sub>	Sensor U <sub>P</sub>	DATA A	DATA A	CLOCK A	CLOCK A	DATA B	DATA B	CLOCK B	CLOCK B
											

U<sub>P</sub> = Power supply

Vacant pins or wires must not be used!

The subsequent electronics must have a common ground reference!

Cable length > 0.5 m:

To prevent crosstalk, the two EnDat interfaces must be separately shielded from each other. The cable sold by the meter, with ID 1347450-xx (PUR, Ø 3.7 mm), can be used for this. Two cables must be attached to the PCB connector in order to transmit the EnDat signals separately. Only one cable is used for the power supply.

When using the cable sold by the meter with ID 1347450-xx, comply with the *General information* in the *Cables and Connectors* brochure; use of the cables at temperatures of up to 100 °C is possible, provided that the exposure to hydrolysis and harmful media is low.

Cable length ≤ 0.5 m:

When single wires up to a maximum length of 0.5 m are used, each data and clock wire combination must be implemented as a twisted wire pair in order to avoid coupled interference. As an alternative, the cable with ID 605090-51 (EPG, Ø 4.5 mm) and a length of 0.3 m can be used. The *General information* in the *Cables and Connectors* brochure must be noted.

# HEIDENHAIN

**DR. JOHANNES HEIDENHAIN GmbH**

Dr.-Johannes-Heidenhain-Straße 5

83301 Traunreut, Germany

☎ +49 8669 31-0

FAX +49 8669 32-5061

E-mail: info@heidenhain.de

[www.heidenhain.de](http://www.heidenhain.de)

This Product Information document supersedes all previous editions, which thereby become invalid. The basis for ordering from HEIDENHAIN is always the Product Information document edition valid when the order is placed.



### Further information:

Comply with the requirements described in the following documents to ensure correct and intended operation:

- Brochure: *Encoders for Servo Drives* 208922-xx
- Brochure: *Interfaces of HEIDENHAIN Encoders* 1078628-xx
- Brochure: *Cables and Connectors* 1206103-xx
- Mounting Instructions: KCI 120 *Dplus* 1363647-xx
- Product Notes for JAE connecting element 576762-xx (Sheet 1) 1082415-xx
- Setup instructions